

# Budget Robotics Rigel Assembly Instructions

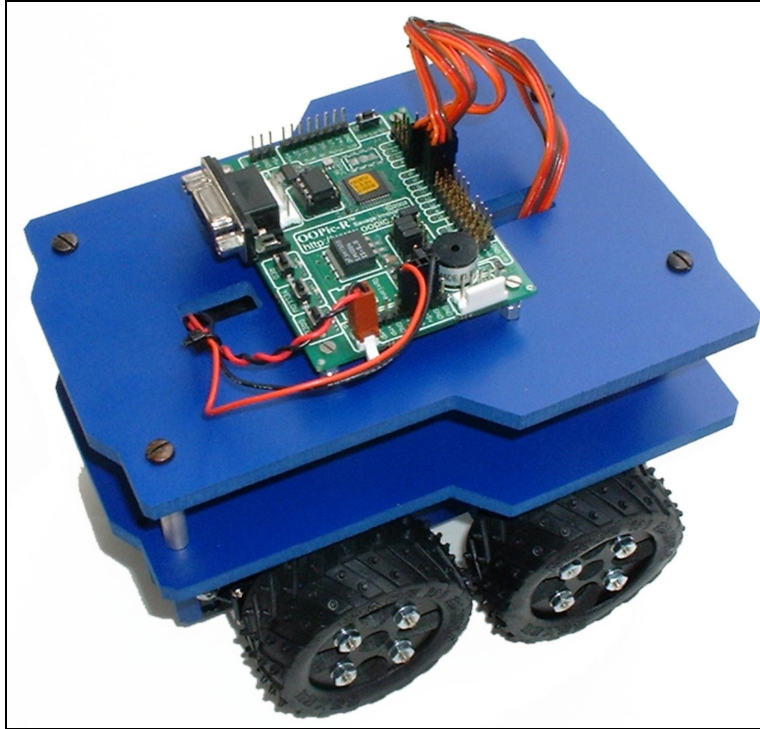

*(Shown with optional microcontroller.)*

The Budget Robotics Rigel kit is a low-cost 4WD (four wheel drive) motor-driven wheeled vehicle. It is designed as a flexible base which you can use to construct a fully-featured robot.

Rigel uses four independent R/C servo motors, and custom rubber-nibbed wheels. Rigel requires less than 20 minutes for assembly. Two decks, or "levels," are provided for mounting batteries, sensors, microcontroller, and other components.

The finished robot measures approximately 6.75" in length, 6" wide, and 4.25" high. Weight without batteries is approximately 23 oz.

Rigel can be used over a variety of flooring: laminated tabletop (e.g. Formica), carpet, tile (all except very smooth/polished), hardwood flooring, concrete, asphalt, grass, and even dirt. When used outdoors exercise care that the servo motors and other components do not become soiled with dirt, moisture, or other contaminants.

Note: Rigel lacks circuitry for controlling the servo motors. Any of a number of microcontrollers can be used for this purpose, and most will fit on either the bottom or top deck of Rigel. As an example, the Parallax Board of Education is a ready-to-go microcontroller that can be readily used with Rigel.

## Parts List

Rigel contains the following parts:

Quantity	Description
1	Bottom deck, with mounting holes for brackets
1	Top deck
2	Servo motor mounting rails (left and right)
2	Servo spacers
2	2" wide plastic gusseted mounting brackets
4	3/4" wide plastic gusseted mounting brackets
4	R/C servo motors, modified for continuous rotation
4	2½" diameter rubber wheels (kit with hubs, mounting hardware, rubber tire, and servo disc)
24	4-40 x 1/2" machine screws
8	4-40 x 3/4" machine screws
32	4-40 hex nuts
16	#4 washers
4	Risers (four aluminum standoffs, 8 machine screws)

# Assembly Steps

## **Step 1-Right Mounting Rail**

Use:

- (1) servo mounting rail (the two rails are identical--chose either)
- (2) 3/4" plastic gusseted brackets
- (1) 2" plastic gusset bracket
- (4) 4-40 x 1/2" machine screws
- (4) 4-40 hex nuts

Using 4-40 x 1/2" machine screws and nuts, mount the 2" and 3/4" plastic gusset brackets as shown. The flat part of the brackets should face upwards.

Finger-tighten the screws and nuts only at this point.

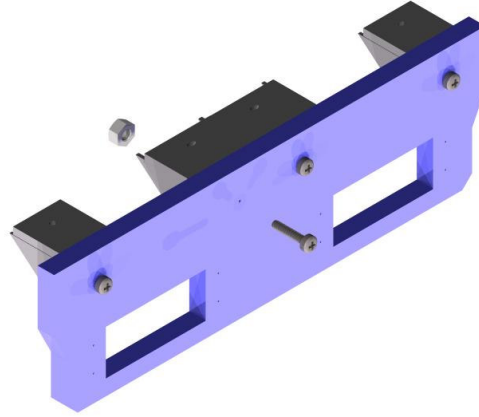

## **Step 2-Left Mounting Rail**

Use:

- (1) servo mounting rail
- (2) 3/4" plastic gusseted brackets
- (1) 2" plastic gusset bracket
- (4) 4-40 x 1/2" machine screws
- (4) 4-40 hex nuts

Repeat the above steps for the left mounting rail. Assembly is in mirror image to the right mounting rail.

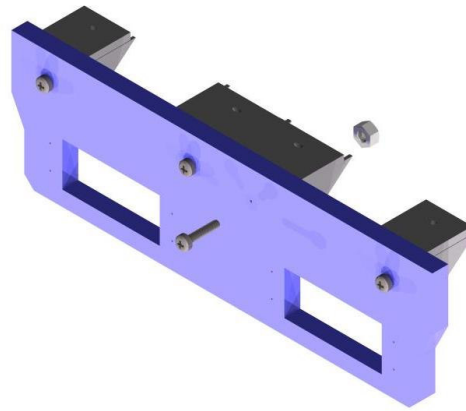

### **Step 3-Bottom Deck**

Use:

- Right mounting rail assembly (from Step 1)
- Left mounting rail assembly (from Step 2)
- (1) Bottom deck
- (8) 4-40 x 1/2" machine screws
- (8) 4-40 hex nuts

Using 4-40 x 1/2" machine screws and 4-40 hex nuts, attach the assembled right and left mounting rails to the bottom deck, as shown. (The bottom deck can be identified by its additional mounting holes.)

Finger-tighten the screws and nuts only until all fasteners have been attached. Then, align the rails with the bottom deck, and tighten with a screwdriver.

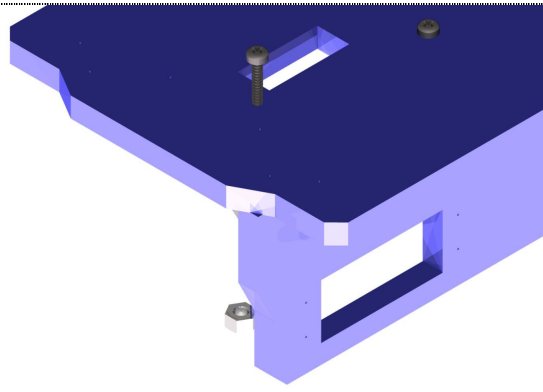

## **Step 4-Right/Left Front Servos**

Use:

- Bottom deck/mounting rail assembly
- (2) Servos
- (2) Servo spacers
- (8) 4-40 x 3/4" machine screws, nuts, and washers

Using 4-40 x 3/4" machine screws, washers, and nuts, install the right front servo, observing the orientation as shown in the illustration. The shaft of the servo should be located toward the middle of the robot. The washer is placed between the screw head and the servo mounting flange. Tighten with a screw driver.

Repeat for the left front servo. Be sure that the servo shaft is located toward the middle of the robot.

(Hint: To make assembly and disassembly easier, you may use only two screws per servo, instead of four. Place the screws on opposite corners of the servo mounting flange.

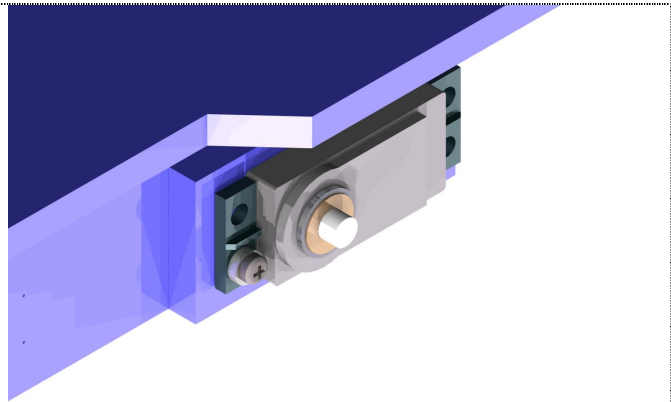

## Step 5-Right/Left Rear Servos

Use:

- Bottom deck/mounting rail assembly
- (2) Servos
- (8) 4-40 x 1/2" machine screws, nuts, and washers

Using 4-40 x 1/2" machine screws, washers, and nuts, install the right rear servo, observing the orientation as shown in the illustration. The shaft of the servo should be located toward the middle of the robot. As in Step 4, the washer is placed between the screw head and the servo mounting flange. Tighten with a screw driver.

Repeat for the left rear servo. Be sure that the servo shaft is located toward the middle of the robot.

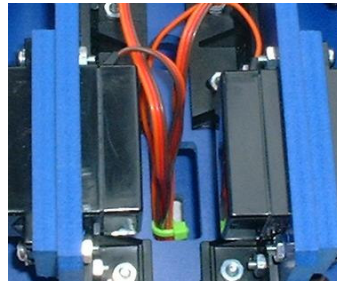
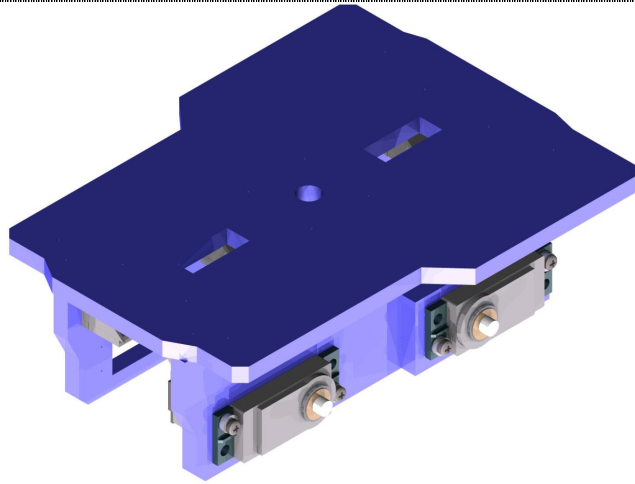

*(Hint: Insert the servo wires through the slots of the bottom deck, and bundle up with 4" nylon cable ties to keep neat.)*

## Step 6-Risers

Use:

- Bottom deck/mounting rail assembly
- (4) Aluminum standoffs (risers)
- (4) Machine screws

Insert four screws into the riser mounting holes of the bottom deck. The screws are inserted from the bottom up.

Hand-tighten four aluminum standoffs onto the screws.

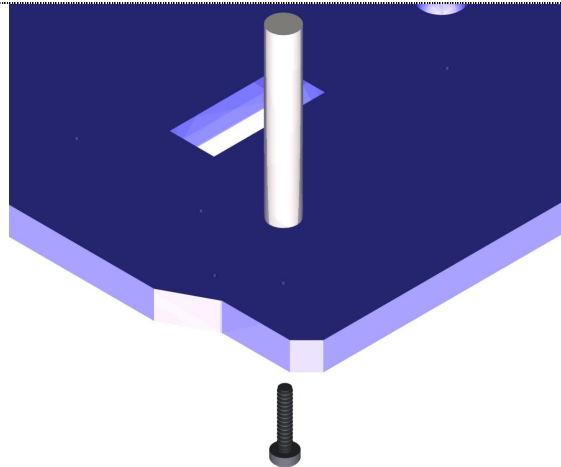

*(Note: For simplicity bottom deck and riser shown only.)*

## **Step 7-Top Deck**

Use:

- Bottom deck/mounting rail assembly
- Top deck
- (4) Machine screws

Insert four screws into the riser mounting holes of the top deck. Secure the screws into the four aluminum standoffs.

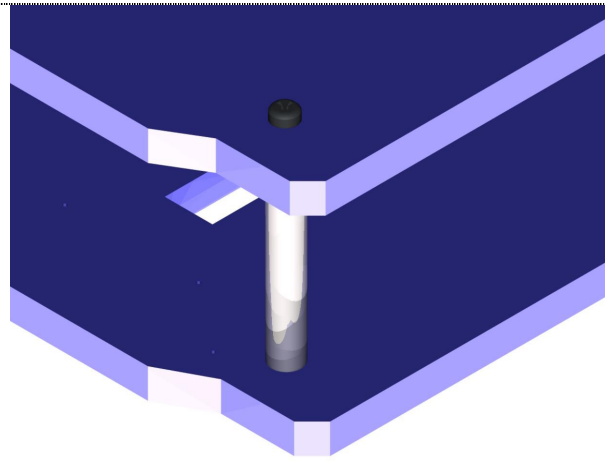

*(Note: For simplicity bottom/top deck and riser shown only.)*

## Step 8-Wheel Assembly

Use:

- (4) Rubber wheel kits

Assemble each of the four wheels as follows (refer to the illustration):

- 1 Push the flange of the white servo disc into the hole of the inside rim.
- 2 Insert a 1" screw into the inside rim and white servo disc.
- 3 Snap shoulder over the servo disc.
- 4 Insert two wheel discs onto the machine screw (the rim piece, shown in the diagram, is added later).
- 5 Thread the washer and nut. Finger tighten only.
- 6 Insert the other three machine screws through the wheel assembly, and finger tighten washers and nuts.
- 7 Use Phillips screwdriver to tighten the screws. Tighten evenly. Do not over tighten.
- 8 Press the rim piece all the way into the rubber tire.
- 9 Press the wheel assemble into the rubber tire. The outside of the tire (marked with writing) faces the side of the wheel with the washers/nuts.

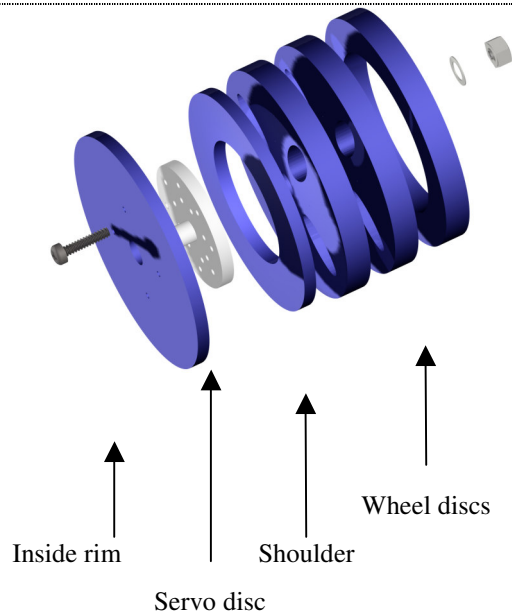

## Step 9-Wheel Mounting

Mount the four assembled wheels onto the four servos. Each servo comes with a small black mounting screw. Remove this screw if already attached to the servo. Place the wheel firmly over the servo shaft, then insert the screw through the hole of the wheel.

Tighten with a small Phillips screwdriver. ***Do not over tighten.***



## Rigel 4WD Robot Kit Notes for Construction and Use

1. Sensors can be mounted on the bottom or top decks, as needed. You are free to add more mounting areas for sensors by using thin strips of aluminum or plastic, either of which are available at most hobby stores. Use small screws to secure these strips in place, rather than glue, in case you need to disassemble Rigel.
2. A microcontroller and battery pack(s) can be mounted on the top or bottom deck. The bottom deck is an ideal location for the batteries. You may secure the battery pack using double-sided foam tape, Velcro, or 3M Dual Lock (available through Budget Robotics). The microcontroller can be conveniently mounted on the top deck. Rigel is made from expanded rigid PVC plastic. This plastic is easy to drill. Mark mounting holes for the microcontroller, and use a hand or motorized drill to make the necessary holes.
3. We recommend the use of high capacity (over 1000 mAh) AA rechargeable batteries. Rigel uses four R/C servo motors, and these motors draw approximately 180 mA each when powered (approx. 10 mA when idle). The servos can be operated at 4.8 to 6 vdc.
4. We **HIGHLY** recommend that you use a dedicated battery pack for the servos. Use a separate battery for the microcontroller and other electronics. Be sure to connect the grounds of both battery supplies, or the system will not work.
5. If a separate battery supply for the servos is not possible, it is better to connect each servo to its own microcontroller output, rather than through a Y-harness. Write your control program so that each servo is pulsed in turn, not at the same time. (For more information on how servos are operated see the section below on *Servo Centering Adjustment*.)

## Servo Centering Adjustment

Rigel uses standard R/C model airplane servo motors that have been modified for continuous rotation. Ordinarily, software running on your servo control circuit or microcontroller is used to set the "center" of the servo. This signal is nominally a repeating pulse of 1.5 milliseconds in duration. When centered, the servo stops all motion. Applying a pulse greater than 1.5 milliseconds causes the servo to rotate in one direction; a pulse of less than 1.5 milliseconds causes the servo to rotate in the other direction. Note this pulse is repeated 30-50 times each second.

If you received a Rigel with GWS S35 motors, these servos do not require electronic centering as they are digitally controlled to center at 1.5 milliseconds. If you received a kit with the GWS S03 motors, these may be fine fine-tuning adjustments to the servo center to best suit the control circuitry you are using.

Should you wish to adjust the physical center of the GWS S03 servo you may do so by following these steps:

1. Remove the wheel from the servo.
2. Remove the servo from the mounting rail.
3. Remove the four casing screws on the servo.
4. Place the servo upright (base down) on the table, and very carefully remove the top casing. Apply gentle finger pressure on the output shaft to prevent the output gear from being pulled out as you remove the casing.
5. Remove the center gear, but keep the metal shaft in place.
6. Remove the output gear. (Minimize handling of the gears so that you don't accidentally "soak up" too much of the white lubricating grease into your fingers. If you think the gears have become insufficiently lubricated, you may apply a small amount of synthetic grease -- available at most electronics stores -- to replenish.)
7. Adjust the feedback potentiometer as required. If needed, you may apply a *very small* amount of Super Glue (or equivalent) to the potentiometer shaft to lock it in place.
8. When done, replace the output and center gear. Replace the top casing and four casing screws of the servo.

Reattach the servo to the mounting rail, and the wheel to the servo.

Rigel is available from:

**Budget Robotics**  
**PO Box 5821**  
**Oceanside, CA 92056**  
**<http://www.budgetrobotics.com/>**  
**[orders@budgetrobotics.com](mailto:orders@budgetrobotics.com)**

122909